

**KALOS**  
INTERCONTINENTAL S.L



**FORNITURE**  
FOTOVOLTAICHE SRL



**SOLUTIONS FOR  
PHOTOVOLTAIC INSTALLATIONS**

# OUR STORY

**Forniture Fotovoltaiche** is **KALOS** partner a company operating in the field of business mediation. Created in 2005 by the **Paolicelli** family to fill a gap in the business landscape of Southern Italy, it is an organisation specialised exclusively in the brokerage of **Renewable Energies**.

The company's main objective is to extend the immense potential of clean energies in an increasingly effective way, enhancing the territory and giving European and international visibility to the business partners with which it collaborates, channelling competences and creating synergies to achieve economies of scale that can benefit the territory.



## LOGISTICS SHIPMENT

- **72 Hours**
- **96 Hours**
- **120 Hours**
- **International  
1 Month**



**2** LOGISTICS  
OFFICES

**+ 100** POINTS OF SALE  
THROUGHOUT EUROPE



**READY FOR THE FUTURE**

**+ 1500**  
Customers

**+ 250MW**  
Sold in 2022

[www.kalosintercontinental.com](http://www.kalosintercontinental.com)

# OUR MAIN ACTIVITY

## INVERTERS AND BATTERIES



SUNGROW

## PHOTOVOTAIC MODULES



LONGI Solar

JASOLAR

Hanover Solar



## COMPONENTS

- ✔ Structure
- ✔ Solar cords
- ✔ Tables
- ✔ Solar thermal
- ✔ Wallbox
- ✔ Optimisers

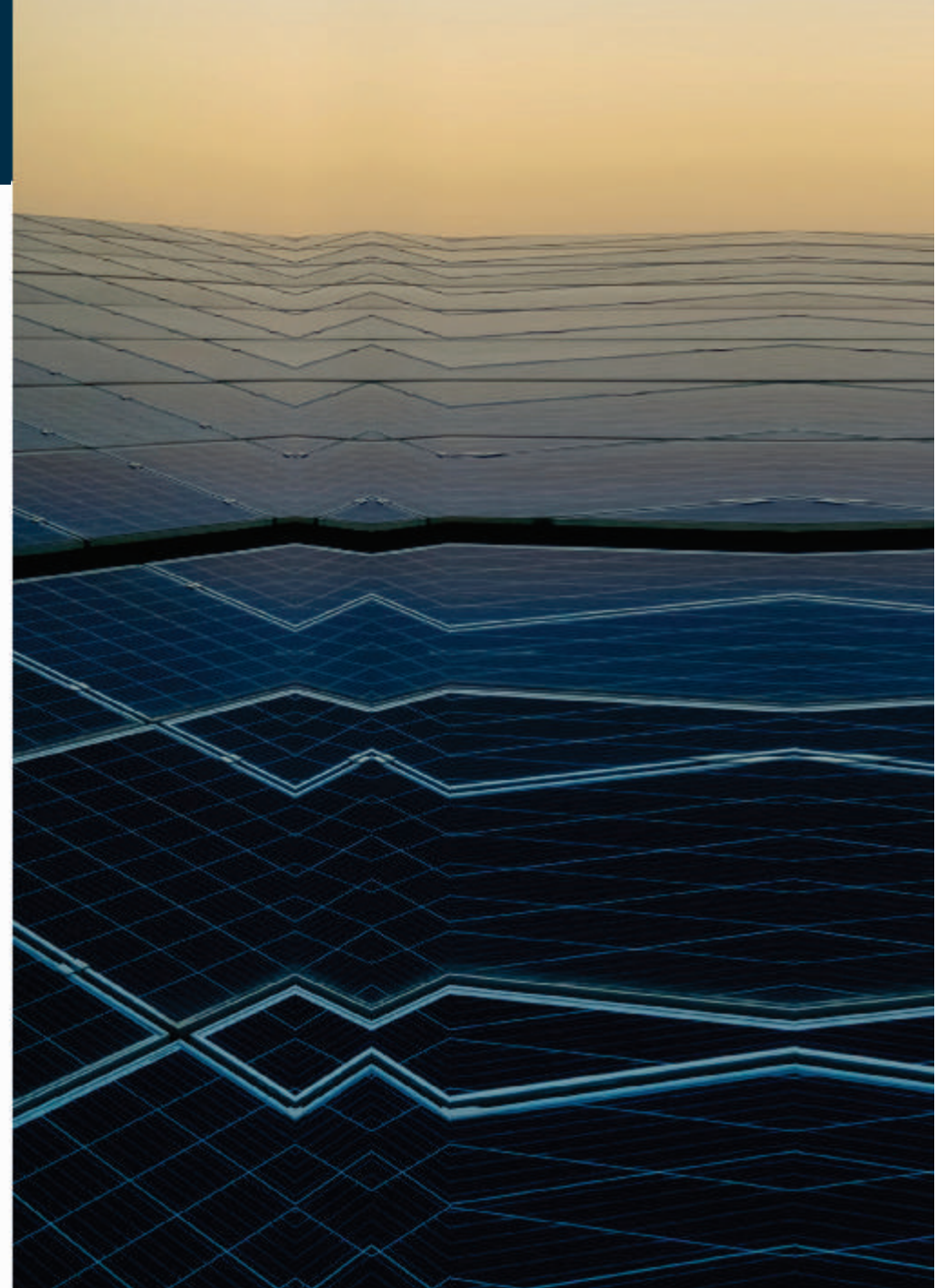



**KALOS**  
INTERCONTINENTAL S.L



**PHOTOVOLTAIC  
MODULE  
PRODUCTION**

**MOBILITY**

**PRODUCT  
SALES**

**ASSIGNMENT  
OF CREDITS**

**OPERATING  
RENTAL**

**TECHNICAL  
SUPPORT**

**BRIDGING  
FINANCE  
IN SOLAR  
CONSTRUCTION**  
**GENERTEC/CNC**

SAJ Customer Service:  
02 8089 8660

## SINGLE-PHASE

- R5-0.7K-S1-15
- R5-1K-S1-15
- R5-1.5K-S1-15
- R5-2K-S1-15
- R5-2.5K-S1-15
- R5-3K-S1-15
- R5-3K-S2-15
- R5-3.6K-S2-15
- R5-4K-S2-15
- R5-5K-S2-15
- R5-6K-S2-15
- R5-7K-S2-15
- R5-8K-S2-15

### Warranty

5 (Standard)  
10/15/20/25 (optional)



## INVERTER 100kWh

- C6-75K-T6
- C6-110K-T12
- C6-100K-T9
- C6-125K-T12

## THREE-PHASE

- R5-3K-T2-15
- R5-4K-T2-15
- R5-5K-T2-15
- R5-6K-T2-15
- R5-8K-T2-15
- R5-10K-T2-15
- R5-12K-T2-15
- R6-15K-T2-32
- R6-17K-T2-32
- R6-20K-T2-32
- R6-25K-T2-32
- R6-30K-T3-32
- R6-33K-T3-32
- R6-36K-T3-32
- R6-40K-T4-32
- R6-50K-T4-32

## TECHNICAL SPECIFICATIONS

### Photovoltaic power + 50% inverter power



Lightning protection, high precision leakage control



APP connection, eSolar all data in real time



Silent, negligible acoustic impact



Low power consumption in sleep mode, high efficiency high performance



Remote maintenance and configuration



Remote maintenance and configuration

# SUNGROW

---

INVESTOR

## SUNGROW

Clean energy for all



Sizes available in store

**40 kW • 50 kW • 110 kW • 250 kW**

[www.kalosintercontinental.com](http://www.kalosintercontinental.com)



# MODULI FOTOVOLTAICI

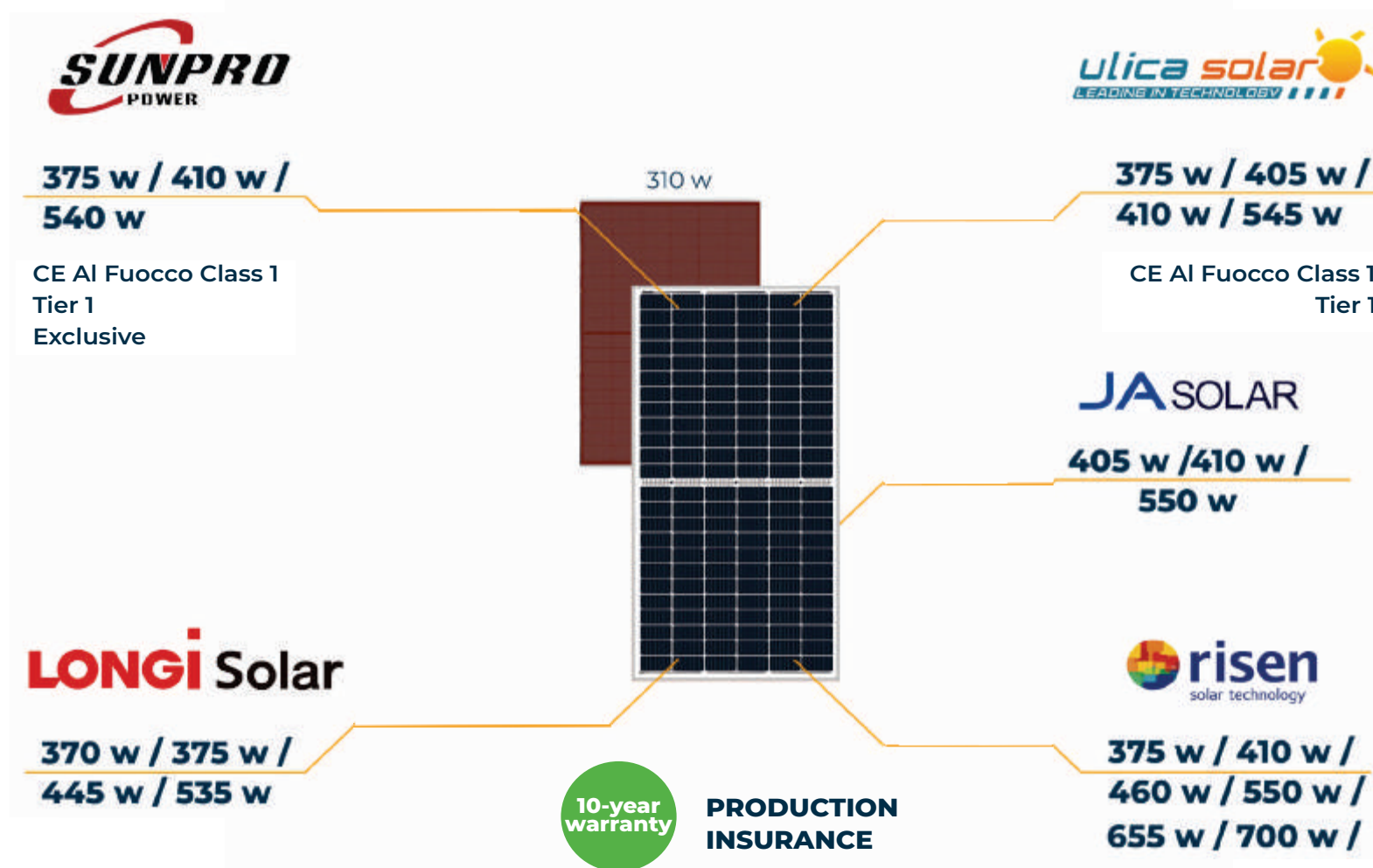

SEE ALSO



**TITAN**

**HIGH PERFORMANCE  
MONO-PERC MODULE**

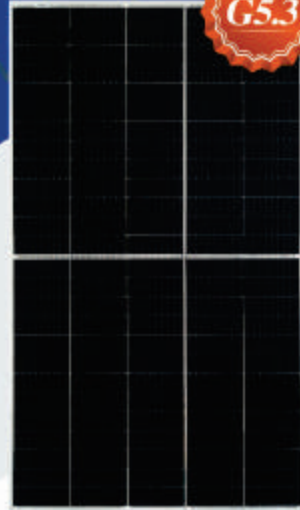

**30-year  
warranty**

**RSM130-8-430M-450M**

**130 CELLS**

MONO-PERC module

**430-450WP**

Output Power Range

**1500VDC**

Maximum system voltage

**21.7 %**

Top performance

**N-TYPE TOPCON**

Technology within the coming years

**540 -740W**

Output Power Range

**Main Features**



Global Tier 1 brand with state-of-the-art automated manufacturing and independent certification



Lowest thermal power ratio in the industry



12-year warranty



Excellent performance with low radiation



Excellent PID resistance



Positive power tolerance (0~+3%)



100% two-stage EL inspection guaranteeing a defect-free product



The Imp Bin module radically reduces chain misalignment losses



Excellent mechanical resistance to wind 2400Pa and snow 5400Pa



Full product and system certification

- ◆ IEC61215:2016; IEC61730-1/-2:2016;
- ◆ NTC ISO 9001: 2015 Quality Management System
- ◆ ISO 14001:2015 Environmental Management System
- ◆ ISO 45001:2018 Occupational Health and Safety Management System

\* As there are different certification requirements in different markets, we recommend that you contact the Risen Energy sales representative in your country to obtain the specific certificates applicable to the products in the country in which they are to be used.

**About Risen Energy**

Risen Energy is one of the world's leading manufacturers of high-performance solar photovoltaic products and a provider of comprehensive business solutions for residential, commercial and utility transformation. Founded in 1986 and listed on the stock exchange since 2010, the company strives to create value for its select customers around the world. Technical and commercial innovation, backed by quality and support, determines Risen Energy's business choices, which are among the most successful and profitable in the industry. Risen Energy's local market presence and financial strength enable it to enter into strategic and mutually beneficial partnerships with its partners, increasing the value of renewable energy.

Zona industrial de Tashan, Meilin, Ninghai 315609, Ningbo | RPC  
Telf.: +86-574-59953239 Fax: +86-574-599535999  
Email: marketing@risenenergy.com Página web: www.risenenergy.com

**OFFICIAL DEALER**



**LINEAR WARRANTY PROVISION**

12-year product warranty/ 25-year linear production warranty

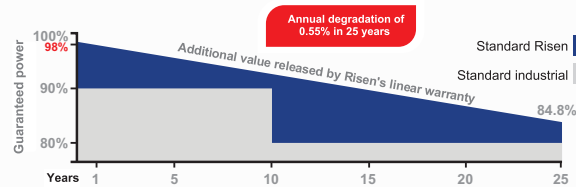

★ Please check the original version of the Limited Product Warranty of fcially issued by Risen Energy CO.

THE POWER OF RISING VALUE



**N-TYPE TOPCON**  
Technology within the coming years

**540 - 740W**  
Output Power Range

# CLAMPING SYSTEMS

Composition Example

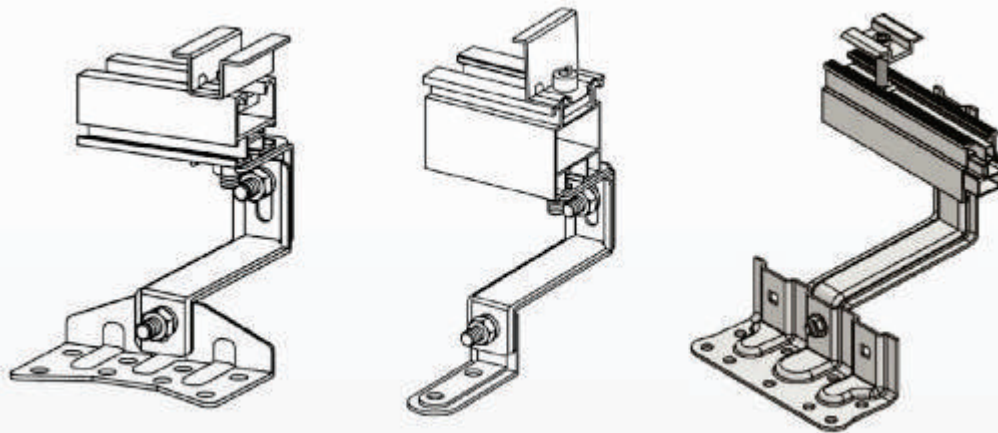



## CLAMPING SYSTEMS

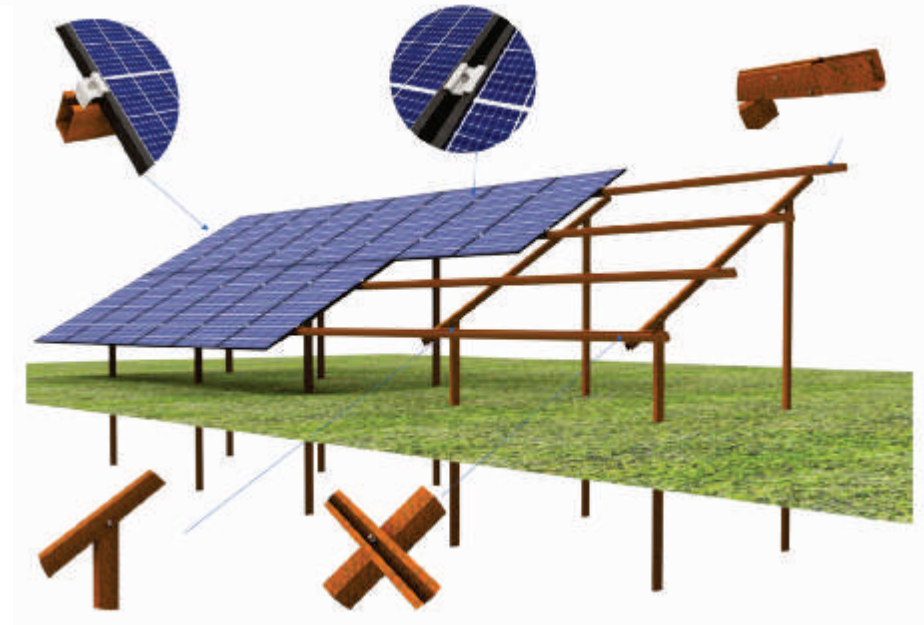

# FUTURE

## Well-Comm Flat Roof Ballast System

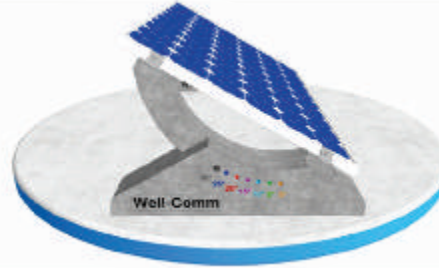
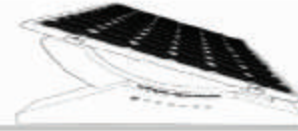

**PARENTED SYSTEM**  
The Well-Comm ballast system is an innovative, patented and therefore copy/counterfeit-protected flat cover system.



**UNIQUE SYSTEM MULTIPLE**  
The Well-Comm system allows, with a single adjustable ballast, the installation of photovoltaic modules at 0° - 5° - 10° - 15° - 20° - 25° - 30°.



**WIND TUNNEL TESTED**  
The Well-Comm system has been wind tunnel tested with rollover resistance validated by TÜV Rheinland for winds above 200 km/h.



**MADE IN ITALY**  
Well-Comm products are made from 100% Italian materials.



**100% RECYCLABLE**  
Well-Comm products are made from 100% recyclable materials.



**25-YEAR WARRANTY**  
Well-Comm products are guaranteed for 25 years from the date of purchase, with unlimited replacement.

### PRODUCT ADVANTAGES

The Well-Comm ballast system is the ideal solution for photovoltaic systems on flat roofs.

- ✓ No perforations in the slab
- ✓ Extremely quick assembly
- ✓ Individual ballast with multiple possible module tilts
- ✓ Threaded bushings for direct attachment of the modules

INFO: [www.well-comm.it](http://www.well-comm.it) - [info@well-commit](mailto:info@well-commit)

### TILT POSITIONING

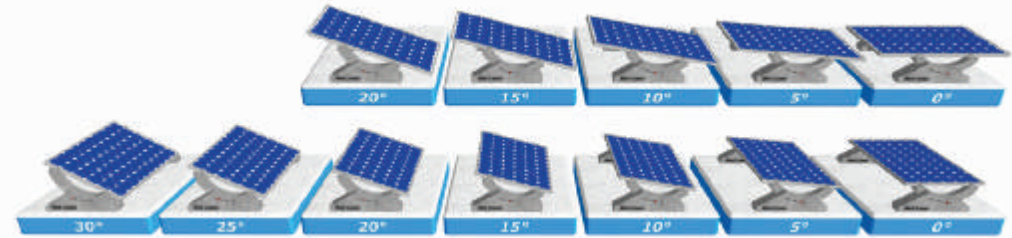

## PRODUCED BY SIPREM MATERA TRIANGULAR BALLAST WITH 10° TILT

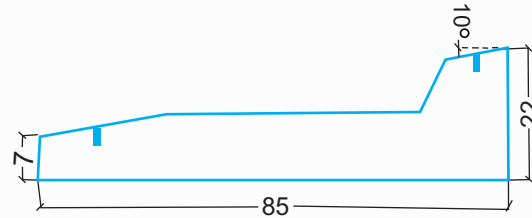

Width = 13cm  
Length = 85cm  
Height = 22,3cm  
Kg = 31

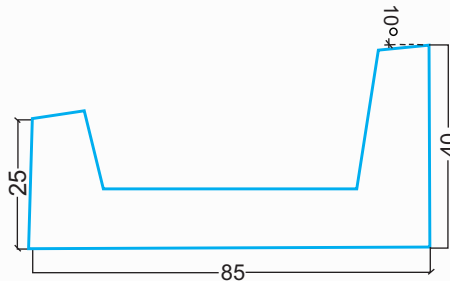

Width = 13cm  
Length = 85cm  
Height = 40cm  
Kg = 46

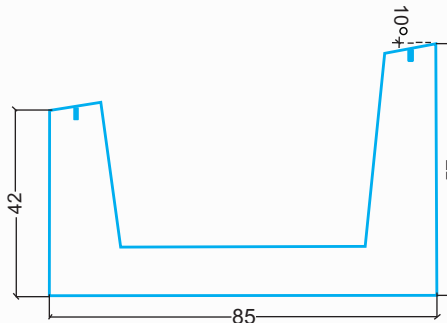

Width = 13cm  
Length = 85cm  
Height = 57cm  
Kg = 62



# KALOS

INTERCONTINENTAL S.L



 [Photovoltaic@kalosintercontinental.com](mailto:Photovoltaic@kalosintercontinental.com)

 [kalosintercontinental.com](http://kalosintercontinental.com)

- 
- Registered Office: Malaga, Rome
  - Headquarters: Malaga, Matera
  - Logistics headquarters: Madrid, Valencia, Milan
- Km 11, 4 Ctra. Cartama, Campanillas  
Malaga. 29590. Espana